

PRECAUTIONS

To avoid any damage to the product, please follow instructions as below:

- Do not allow non-technical staff to transform, disassemble, or repair the product. If the product needs to be repaired, please contact supplier.
- Do not stab, twist, or stretch the power adapter cord. Do not place electric cord in proximity to high temperatures or put heavy pressure on the cord. Cutting or repairing the cord is not allowed.
- If the cord of the adapter is damaged, or the socket is loose, do not use the unit.
- To ensure optimum operation, each time after using the diffuser, drain the water out of the water tank and use a cloth to wipe it clean.
- Do not plug in the adapter in wet areas, such as a bathroom, sauna, greenhouse, etc.
- If there is an unusual smell, noise or abnormal function, then the product or the adapter may be faulty. Please remove the adapter from the supply socket and discontinue use.
- Do not fill the diffuser with water from the tap directly. Use the measuring cup provided to add water into the water tank.
- Essential oil can cause stains, so if a spill occurs, use a cloth to wipe immediately.
- Do not let the mist outlet spray directly on furniture, clothes or walls. Avoid placing the diffuser in direct sunlight, or close to an air conditioner, fan or high temperatures.
- Do not block the mist outlet. This may cause damage to the diffuser.
- Place the diffuser unit on a flat, level surface and avoid placing on appliances such as a TV, or audio equipment.
- After extended periods of operation, in order to avoid damaging the ultrasonic plate, the unit should be turned off for 60 minutes.
- Do not move diffuser while in operation.
- Do not touch the product while your hands are wet, in order to avoid risk of electric shock.
- The diffuser should be kept out of reach of children.
- This product is not suitable for children.
- Please read all information in this user manual before operating.

FAULT CAUSES

If the diffuser unit does not work correctly, please check the following troubleshooting guide before contacting the supplier for repair.

FAULT	POTENTIAL CAUSE
When you turn on the product, the power shuts off within 1 second	<ul style="list-style-type: none">• Confirm whether the tank has water or not. Is the water volume enough? -- Please add water into the tank.• Is the AC adapter connected correctly? -- Please confirm the product is well connected with the adapter. In order to confirm the connection is OK, pull the DC socket out of the product, and reconnect it.
Ultrasonic diffuser is leaking water	<ul style="list-style-type: none">• Is the upper cover securely on the base? -- Remove the upper cover and re-connect it.• Is the temperature too high or too low? -- If the temperature is too low or the humidity is high, the mist may be condensing on the surface and forming water drops.

FAULT	POTENTIAL CAUSE
Mist is not spraying out or is spraying abnormally	<ul style="list-style-type: none">• Is there enough water volume in the tank? -- Please add enough water into the water tank. If the water level is over max line, it may also cause a fault to the mist spray.• Is the ultrasonic atomizing pad dirty? -- Please clean the container. (Please refer to the "maintenance" section)• Is the bottom of the air intake full of dust? -- Please clean the underside of the unit container. If the base inlet is sticky with dust, this will restrict air for the mist spray and will greatly decrease mist volume.

ultrasonic
Oil Diffuser

User Manual

Black
Stone
Finish



SPECIFICATIONS

Stock Code: 0256

This Oil Diffuser uses ultrasonic waves to instantly vaporize water and essential oil/ fragrant oil in the tank, producing a cool, fresh fragrant mist.

Product Size	(Ø)90mm x (H)180mm
Net Weight	Approx. 490g
Voltage	AC 100 - 240V / DC 24V
Power Output	Approx. 12W
Working Mode	Continuous spray / Intermittent mist spray (30 sec ON / 30 sec OFF)
Capacity	100ml
Mist Amount	20-30 ml/hr
Material	PP + Ceramic
Ultrasonic Rate	2.4MHz
Accessories	AC power adapter, Measuring cup, User manual

PRODUCT DIAGRAM

- A. Mist Outlet
- B. Upper Cover
- C. Inner Cover
- D. Air Outlet
- E. Water Tank
- F. Base
- G. LIGHT Button
- H. MIST Button
- I. Air Intake
- J. DC Socket
- K. Water Outlet

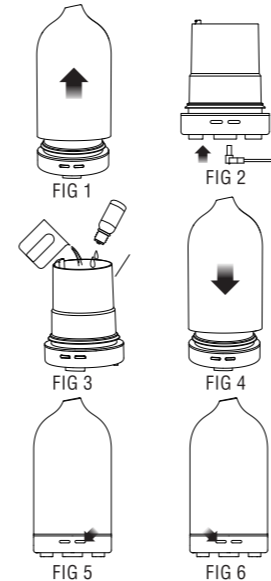
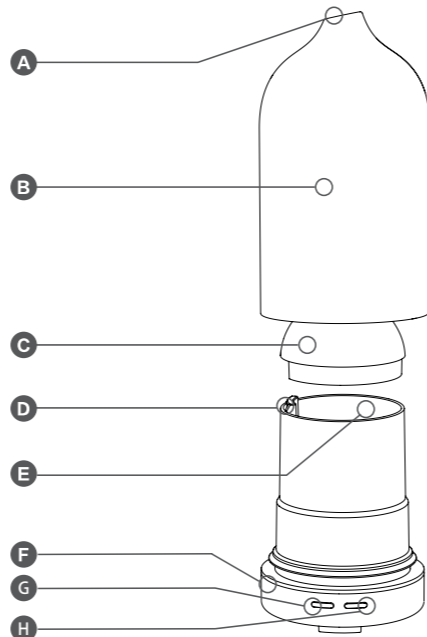
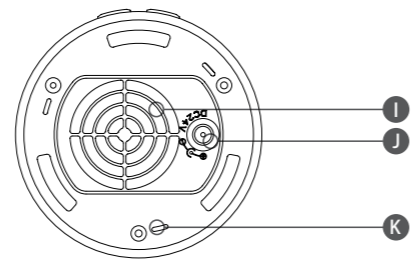

OPERATION

- Place the unit correct side up and remove the upper cover. (FIG 1)
- Connect the AC adapter to the DC jack on the base. (FIG 2)
- Using the measuring cup, fill the water tank with tap water up to the max water level line. *Do not overfill or mist output will be reduced. *Do not use hot water. *Never fill with water during operation.
- Drop essential oil into water tank. (About 0.1mL-0.15mL per 100mL water) (FIG 3)
- Replace the upper cover onto the base. (FIG 4)
Attention: The upper cover must be attached when product is in use.
- Connect the AC adapter with power supply socket.
- Right Button = MIST:
1st Press: Start a continuous mist spray pattern;
2nd Press: Start intermittent mist spray pattern (30 sec ON / 30 sec OFF);
3rd Press: Turn off the mist.
Press mist button for 3 seconds at any time to turn unit off. (FIG 5)
- Left Button = LIGHT:
1st Press: Bright white LED illumination mode.
2nd Press: Soft white LED illumination mode.
3rd Press: Turns light off.
Press and hold light button for 3 seconds at any time to turn light off. (FIG 6)
- The unit turns off automatically when it is out of water.

ATTENTION

- If you do not use the diffuser for a long time, please drain out the water from tank water, dry and then store safely.
- The diffuser will auto shut off when unit is out of water.
- The diffuser will not work without water.
- The amount and intensity of mist produced will vary, but this is not unusual and should not be considered as a fault. Factors that affect this include water type, humidity, temperature and air currents.
- We recommend that you clean the unit each time you change oils. Oils are corrosive and over time, they build up on the atomizing plate.

ACCIDENTAL LEAKAGE

In the event of the unit being knocked over or tipped during usage, please follow the instructions as below:

- Unplug the unit and remove the cover.
- Pour any remaining water out of the water tank.
- Shake the unit gently to drain any water inside the mechanism, and then allow to dry for at least 24 hours.

MAINTENANCE

After using 5-6 times, or 3-5 days, please clean the product as below.

- Unplug the unit from power supply and remove the cover.
- Pour any remaining water out from the "DRAIN SIDE" of the water tank.
- Add some warm water into tank and mix with neutral detergent, wash with a cleaning cloth.
- If you find any dirt in the air outlet, please remove the container cover and clean it.
- Never use other acids, enzymes or detergents, as this may risk toxic fumes being generated or cause a malfunction.

BUCKLEY & PHILLIPS AROMATICS

Lilydale Vic. 3140 AUS. (03) 9735 3755

WWW.BUCKLEYANDPHILLIPS.COM